

Installation Guide

Composite Decking & Tri I

STORAGE

APR Composites decking is best stored on a flat dry surface under cover.

Do not leave the product in the sun uncovered, as the graphite colour in particular, will absorb heat over and above the ambient temperature.

INSTALLATION

Correct installation of your composite deck is important and will ensure longevity of your structure.

As composite products expand and contract with temperature variations, it is advisable to choose a day where the temperature is not too extreme. 25° C is probably an ideal installation temperature.

To work out how wide the final decking board of your project will be, divide the total deck width by the width of a decking board, plus the board gap. The width of the final board should be as wide as possible. This can be varied by changing the board gap width from 3mm to 6mm. Once you have determined your ideal gap width, you will need a spacer of that width to use as a template for locating each board.

FIXING THE BOARDS

Typically the composite decking or Tri I is fixed to a composite or timber joist.

The following screws are recommended for both materials, as is the pilot drilling chart below.

We recommend 14G x 100 Class 3 galvanised batten screws (available at most hardware stores) with 5mm hex drive for fixing all of our composite decking materials.

You will need an impact driver, or drill with clutch drive for screw driving, along with the appropriate 5mm hex driver.

It is critical to pre-drill the board and joist holes. Use the following chart to pilot drill the joists and clearance drill the decking board. The decking board hole has to be countersunk using a counter sinking bit.

GAUGE	METRIC EQUIVALENT (mm)	PILOT HOLE (mm)	CLEARANCE HOLE (mm)
8	4.0	3.0	4.5
10	5.0	3.5	5.5
12	5.5	4.0	6.0
14	6.5	5.0	7.0

FIXING TO CONCRETE

If the composite decking is to be fixed to concrete, it is recommended that timber or composite joists be fixed to the concrete using brackets and dynabolts.

FIXING TO STEEL

If the composite decking is to be fixed to steel, the thickness of the steel will determine the approach taken. If it is thick, (4mm or more), then it would be better to fix a composite joist to the steel and then fix the decking to that. If it is less than 4mm, pre-drill using the pilot drilling chart and use galvanised metal drilling 14g x 75mm bugle head batten screws (5mm in hex drive).

Please refer to *Figure 1: Standard Boardwalk Layout Diagram* on Page 2 for further information.

Installation Guide

Composite Decking & Tri I

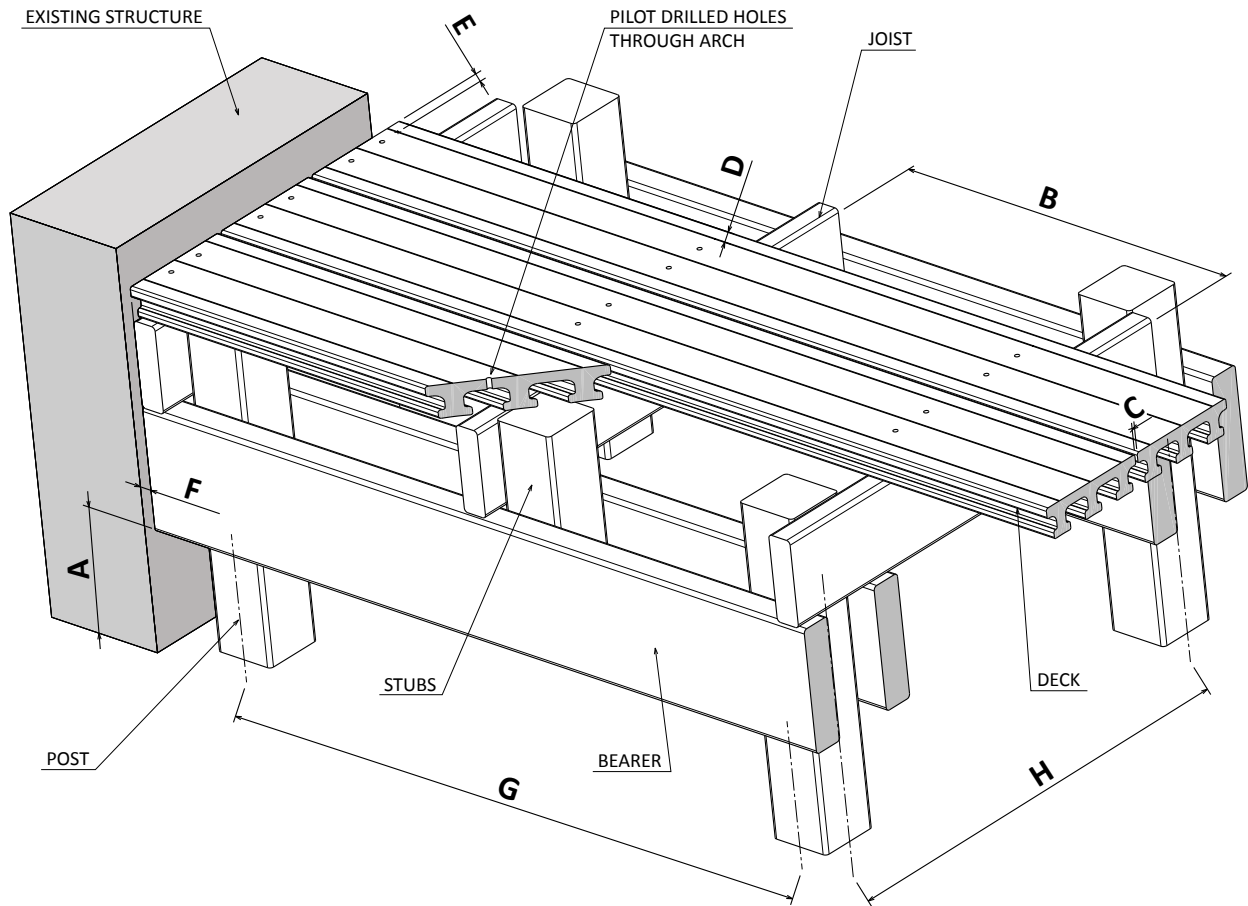

Figure 1: Standard Boardwalk Layout Diagram.

Please refer to APR Technical Specifications for more detailed maximum joist span information.

DIMENSION CHART TO SUIT THE STANDARD BOARDWALK LAYOUT DRAWING:

A	Clearance to underside of rail	50mm
B	Joist centres (max)	300 - 1200mm
C	Board gap	3 - 6mm
D	Distance from board edge to screw hole (min)	20mm
E	Distance from board end to screw hole (min)	20mm
F	Gap between board and fixed structures	6mm
G	Bearer span (between post centres)	1200 - 3200mm
H	Joist span (between post centres)	Refer to APR Tech Specs.

For further information please contact:

APR Composites

29-33 Woomera Ave
Edinburgh, SA 5111

08 8359 4999

sales@aprcomposites.com.au

aprcomposites.com.au